

SPECIFICATION FOR APPROVAL

Product Name	RADIAL CHOKE COIL (LEAD FREE)	Page	1
Tai-Tech Part No.	S0809-1 STAND-OFF SERIES		

1. CONFIGURATION & DIMENSIONS :

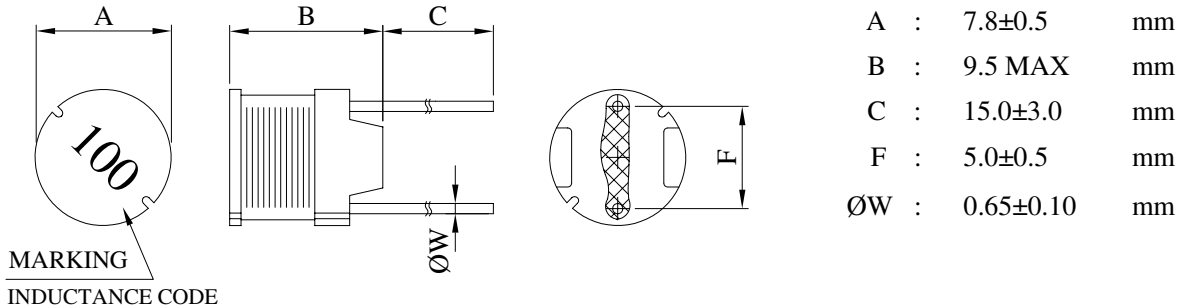

2. SCHEMATIC DIAGRAM :

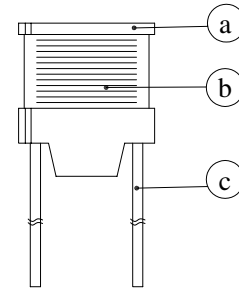
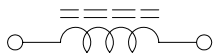

3. MATERIALS :

NO.	DESCRIPTION	SPECIFICATION	REMARK
a.	CORE	DR FERRITE CORE	
b.	WIRE	ENAMELLED COPPER WIRE	
c.	LEAD	TINNED COPPER WIRE	
d.	ADHESIVE	EPOXY	

4. GENERAL SPECIFICATION :

- a) THE INDUCTANCE DROP AT RATED CURRENT IS 10% MAX.
- b) TEMP. RISE : 40°C MAX. AT RATED CURRENT.
- c) STORAGE TEMP. : -40°C ----- +125°C
- d) OPERATING TEMP. : -25°C ----- +85°C



RoHS Compliant

NOTE : Specifications subject to change without notice. Please check our website for latest information.

04.09.2006



TAI-TECH ADVANCED ELECTRONICS (S) PTE LTD

SPECIFICATION FOR APPROVAL

Product Name	RADIAL CHOKE COIL (LEAD FREE)	Page	2
Tai-Tech Part No.	S0809-1 STAND-OFF SERIES		

5. ELECTRICAL CHARACTERISTICS :

PART NO.	INDUCTANCE (μ H)	TEST FREQ. (HZ)	RDC (Ohm) MAX	IDC (A) MAX
S0809-100M2R6-1F	10 \pm 20%	2.52M	0.04	2.60
S0809-120M2R6-1F	12 \pm 20%	2.52M	0.04	2.60
S0809-150K2R1-1F	15 \pm 10%	2.52M	0.05	2.10
S0809-180K2R0-1F	18 \pm 10%	2.52M	0.05	2.00
S0809-220K1R7-1F	22 \pm 10%	2.52M	0.06	1.70
S0809-270K1R6-1F	27 \pm 10%	2.52M	0.06	1.60
S0809-330K1R4-1F	33 \pm 10%	2.52M	0.07	1.40
S0809-390K1R4-1F	39 \pm 10%	2.52M	0.08	1.40
S0809-470K1R3-1F	47 \pm 10%	2.52M	0.10	1.30
S0809-560K1R2-1F	56 \pm 10%	2.52M	0.11	1.20
S0809-680K1R1-1F	68 \pm 10%	2.52M	0.14	1.100
S0809-820K1R0-1F	82 \pm 10%	2.52M	0.16	1.000
S0809-101KR90-1F	100 \pm 10%	1K	0.19	0.900
S0809-121KR82-1F	120 \pm 10%	1K	0.22	0.820
S0809-151KR74-1F	150 \pm 10%	1K	0.27	0.740
S0809-181KR71-1F	180 \pm 10%	1K	0.31	0.710
S0809-221KR64-1F	220 \pm 10%	1K	0.38	0.640
S0809-271KR57-1F	270 \pm 10%	1K	0.53	0.570
S0809-331KR51-1F	330 \pm 10%	1K	0.61	0.510
S0809-391KR48-1F	390 \pm 10%	1K	0.69	0.480
S0809-471KR43-1F	470 \pm 10%	1K	0.89	0.430
S0809-561KR40-1F	560 \pm 10%	1K	1.01	0.400
S0809-681KR35-1F	680 \pm 10%	1K	1.18	0.350
S0809-821KR32-1F	820 \pm 10%	1K	1.57	0.320
S0809-102KR30-1F	1000 \pm 10%	1K	1.84	0.300



RoHS Compliant

NOTE : Specifications subject to change without notice. Please check our website for latest information.

04.09.2006



TAI-TECH ADVANCED ELECTRONICS (S) PTE LTD

SPECIFICATION FOR APPROVAL

Product Name	RADIAL CHOKE COIL (LEAD FREE)	Page	3
Tai-Tech Part No.	S0809-1 STAND-OFF SERIES		

6. CHARACTERISTICS CURVES :

@ TEMP. RISE VS. DC SUPERPOSITION RESPONSE CURVE

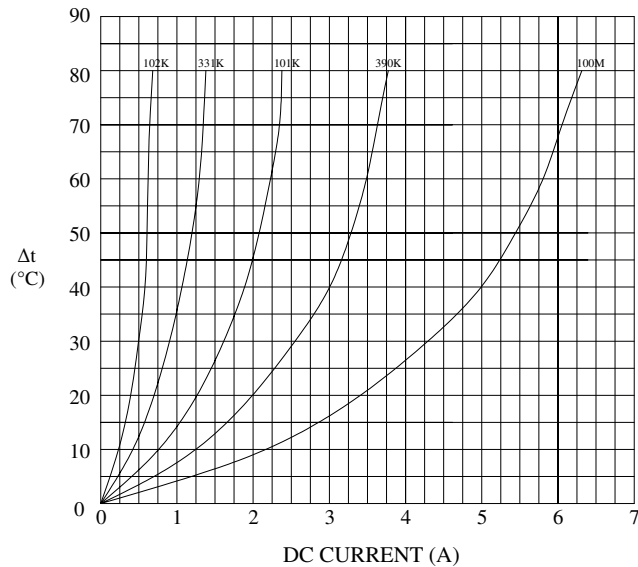

@ INDUCTANCE VS. FREQUENCY RESPONSE CURVE

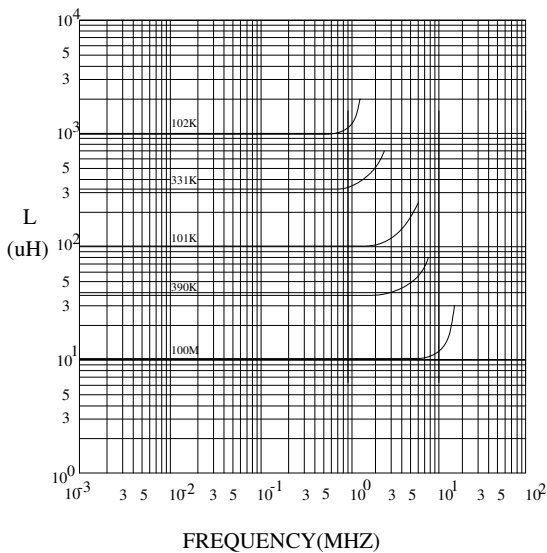

@ INDUCTANCE VS. DC SUPERPOSITION RESPONSE CURVE

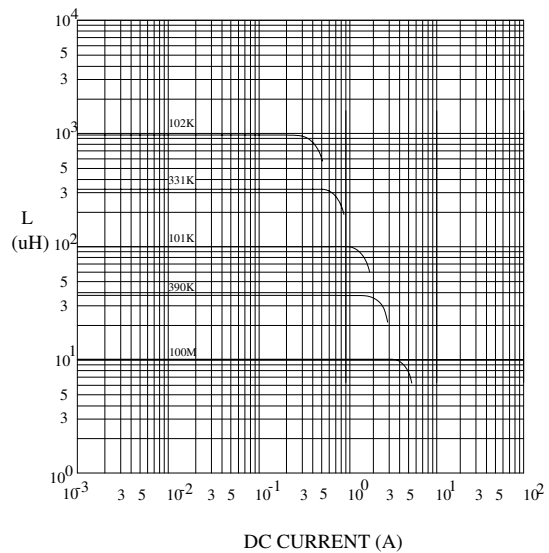

RoHS Compliant

NOTE : Specifications subject to change without notice. Please check our website for latest information.

04.09.2006



TAI-TECH ADVANCED ELECTRONICS (S) PTE LTD