

# SPECIFICATION FOR APPROVAL

Product Name	RADIAL CHOKE COIL (LEAD FREE)	Page	1
Tai-Tech Part No.	S0605-1 STAND-OFF SERIES		

## 1. CONFIGURATION & DIMENSIONS :

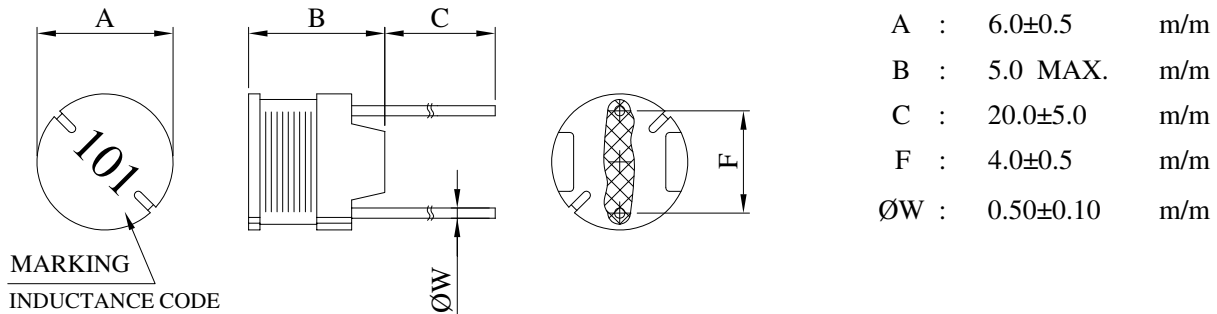

## 2. SCHEMATIC DIAGRAM :

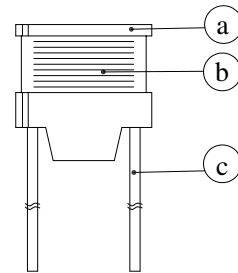
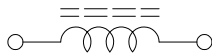

## 3. MATERIALS :

NO.	DESCRIPTION	SPECIFICATION	REMARK
a.	CORE	DR FERRITE CORE	
b.	WIRE	ENAMELLED COPPER WIRE	
c.	LEAD	TINNED COPPER WIRE	
d.	ADHESIVE	EPOXY	

## 4. GENERAL SPECIFICATION :

- a. THE INDUCTANCE DROP AT RATED CURRENT IS 10% MAX.
- b. TEMP. RISE : 40°C MAX. AT RATED CURRENT.
- c. STORAGE TEMP. : -40°C ----- +125°C
- d. OPERATING TEMP. : -25°C ----- +85°C



**RoHS Compliant**

*NOTE : Specifications subject to change without notice. Please check our website for latest information.*

04.09.2006



**TAI-TECH ADVANCED ELECTRONICS (S) PTE LTD**

# SPECIFICATION FOR APPROVAL

Product Name	RADIAL CHOKE COIL (LEAD FREE)	Page	2
Tai-Tech Part No.	S0605-1 STAND-OFF SERIES		

## 5. ELECTRICAL CHARACTERISTICS :

PART NO.	INDUCTANCE ( $\mu$ H)	TEST FREQ. (HZ)	RDC (Ohm) MAX	IDC (A) MAX
S0605-220KR90-1F	22 $\pm$ 10%	2.52M	0.18	0.90
S0605-270KR81-1F	27 $\pm$ 10%	2.52M	0.21	0.81
S0605-330KR74-1F	33 $\pm$ 10%	2.52M	0.27	0.74
S0605-390KR68-1F	39 $\pm$ 10%	2.52M	0.29	0.68
S0605-470KR62-1F	47 $\pm$ 10%	2.52M	0.34	0.62
S0605-560KR57-1F	56 $\pm$ 10%	2.52M	0.42	0.57
S0605-680KR51-1F	68 $\pm$ 10%	2.52M	0.48	0.51
S0605-820KR47-1F	82 $\pm$ 10%	2.52M	0.55	0.47
S0605-101KR42-1F	100 $\pm$ 10%	1K	0.68	0.42
S0605-121KR39-1F	120 $\pm$ 10%	1K	0.77	0.39
S0605-151KR35-1F	150 $\pm$ 10%	1K	0.95	0.35
S0605-181KR32-1F	180 $\pm$ 10%	1K	1.15	0.32
S0605-221KR29-1F	220 $\pm$ 10%	1K	1.30	0.29
S0605-271KR26-1F	270 $\pm$ 10%	1K	1.55	0.26
S0605-331KR23-1F	330 $\pm$ 10%	1K	2.18	0.23
S0605-391KR21-1F	390 $\pm$ 10%	1K	2.47	0.21
S0605-471KR20-1F	470 $\pm$ 10%	1K	2.92	0.20
S0605-561KR18-1F	560 $\pm$ 10%	1K	3.97	0.18
S0605-681KR16-1F	680 $\pm$ 10%	1K	4.57	0.16
S0605-821KR15-1F	820 $\pm$ 10%	1K	5.28	0.15
S0605-102KR13-1F	1000 $\pm$ 10%	1K	7.06	0.13



RoHS Compliant

NOTE : Specifications subject to change without notice. Please check our website for latest information.

04.09.2006



TAI-TECH ADVANCED ELECTRONICS (S) PTE LTD

# SPECIFICATION FOR APPROVAL

Product Name	RADIAL CHOKE COIL (LEAD FREE)	Page	3
Tai-Tech Part No.	S0605-1 STAND-OFF SERIES		

## 6. CHARACTERISTICS CURVES :

@ TEMP. RISE VS. DC SUPERPOSITION RESPONSE CURVE

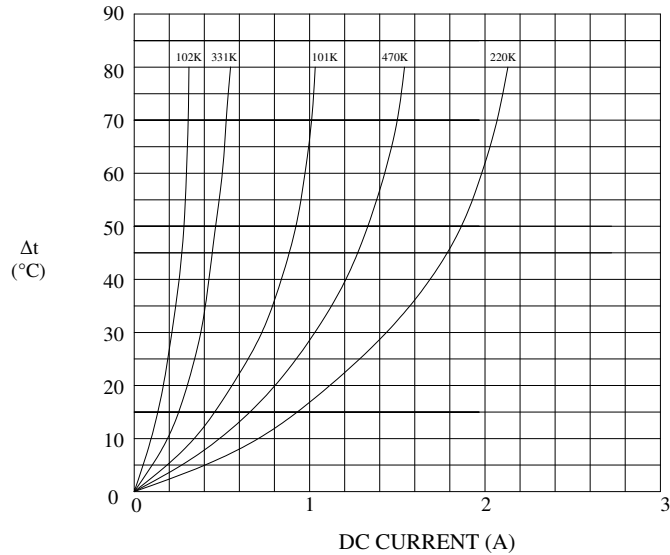

@ INDUCTANCE VS. FREQUENCY RESPONSE CURVE

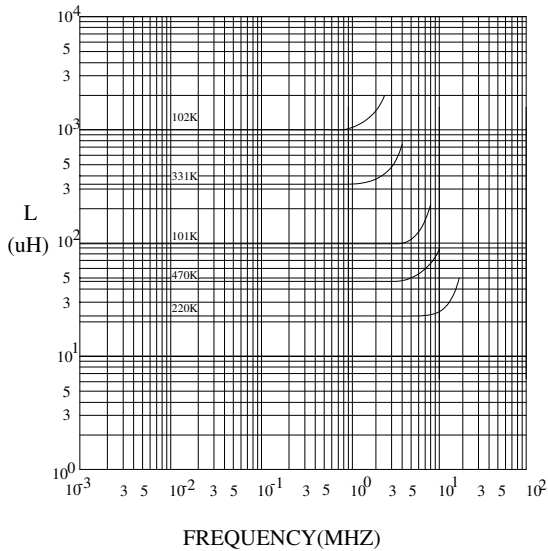

@ INDUCTANCE VS. DC SUPERPOSITION RESPONSE CURVE

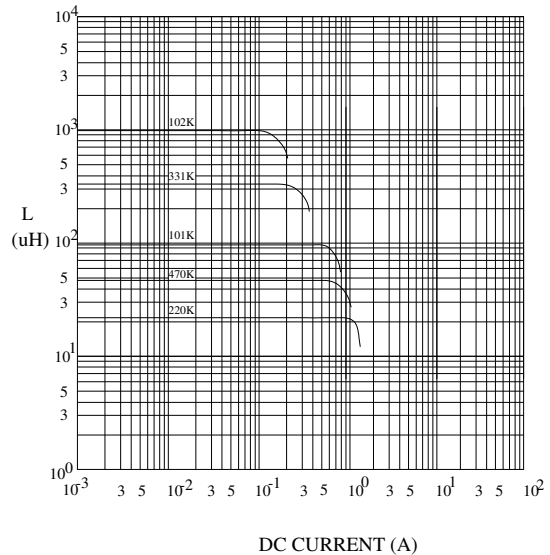

**RoHS Compliant**

NOTE : Specifications subject to change without notice. Please check our website for latest information.

04.09.2006



**TAI-TECH ADVANCED ELECTRONICS (S) PTE LTD**